



Tirane, Albania, Street "Ibrahim Rugova", Building no.28, No.9, Ap.3
Vlore, Albania, Street "Fejzo Gjomema", Building no. P28/155-N

HISTORY

The company "Ds Drilling" Ltd, registered with the commercial name "Alb Sonda", is a name created in the field of construction, which was established in 1996 and has grown, becoming one of the leading companies in the market of construction in Albania. This company is specified in the first phase of construction by making an important contribution to the construction of large works such as water supply, roads, bridges, hydropower plants, geological studies etc. The main objectives of this company are to understand the needs and requirements of its customers by introducing high quality machinery that meets these requirements. Continuous investment in the company creates high credibility of its customers. Alb Sonda Company boasts with the fact that it is able to respond to the needs of clients in the domestic and foreign markets, cooperating with large companies and thus creating a name that differentiates it from other similar services offered by the market. The differentiation depends not only on the price or performance but from the experience of the years operating in this market. Only in this way the company can promise and continue to lead to superior value customers, compared to competitors.



Fig.1 Works during TAP Project in Vithkuq

About Special Foundations

This is a reference to piling techniques that are constructed under a stabilizing fluid to maintain integrity. Specific techniques include Diaphragm Wall, Bored Pile, Barrette, and Cut off Wall. Alb Sonda sh.p.k. is a company operating in the special foundation works sector for over twenty five years. The specialization areas belong to the whole range of special underground works (special foundations) and in particular the consolidation of foundation soils, rocky walls or tunnel faces (consolidation), and the poles for support and / or consolidation of shallow foundations in the field of residential or industrial buildings (piling) and Engineered Ground Improvement sector. Aside them, we offer other kind of works such as steel piles and steel sheet piles walls and combi-wall, micropiles, concrete bored piles, jet grouting, bored ground anchors and tie-rods, "Rock socket" works.



Fig.2 Works during TAP Project in Vithkuq

With the experience gained over time, and the many interventions made, our company offers the full range of practical solutions addressing the specific geotechnical problems from a technical and economic point of view. The presence of highly qualified personnel selected over the years, so as appropriate equipment, makes Alb Sonda sh.p.k., one of the most interesting realities in Albania

- **Secant Bored Piles**

Closely spaced bored piles can be used to form a retaining wall, perhaps for the construction of a deep basement or a cut and cover tunnel. The piles may be constructed so that they virtually touch each other (contiguous). The gaps between the piles can be grouted to form a watertight retaining wall.

Alternatively (secant piles) every other pile may be constructed, with their centres less than two diameters apart. In-fill piles are then bored, cutting into the adjacent piles to form a continuous structure. To aid construction, the first sets of piles may be cast with a lower grade of concrete. These may not be load-bearing and act as 'seals' between the main load bearing piles.

As the piles interlock, this form of construction leads to a more efficient form of structure. During excavation of the soil, the piles will generally require propping before the permanent floor and/or roof structure are completed

Because of the form of construction, the exposed piles will be fairly rough in appearance. Thus, in most cases, an inner wall, which may or may not be structural, will be built or some decorative surface applied, e.g. sprayed concrete or cladding. A method of drainage will generally be required between the piles and any inner wall.

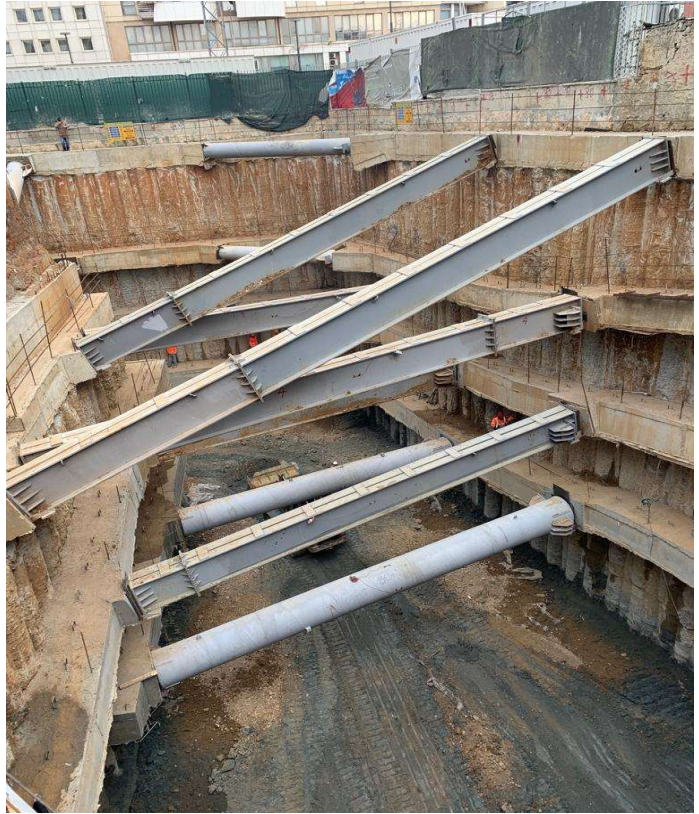

- **Jet grouting, bored ground anchors and tie-rods, “Rock socket” works**

Micropiles

A “multipurpose” technology in foundation engineering.

Structural elements (100 350 mm diameter, 30 35 m average length) for :

- Deep Foundations
- Underpinning Foundations
 - Soil Nailing
 - Retaining Walls
- Tunnel Construction

Main Advantages:

- All range of soils and rocks
- High bearing capacity in comparison with drilling holediameter
- Capability to overpass preexisting foundations
- Use of light weighting and small sized drilling rigs in restricted

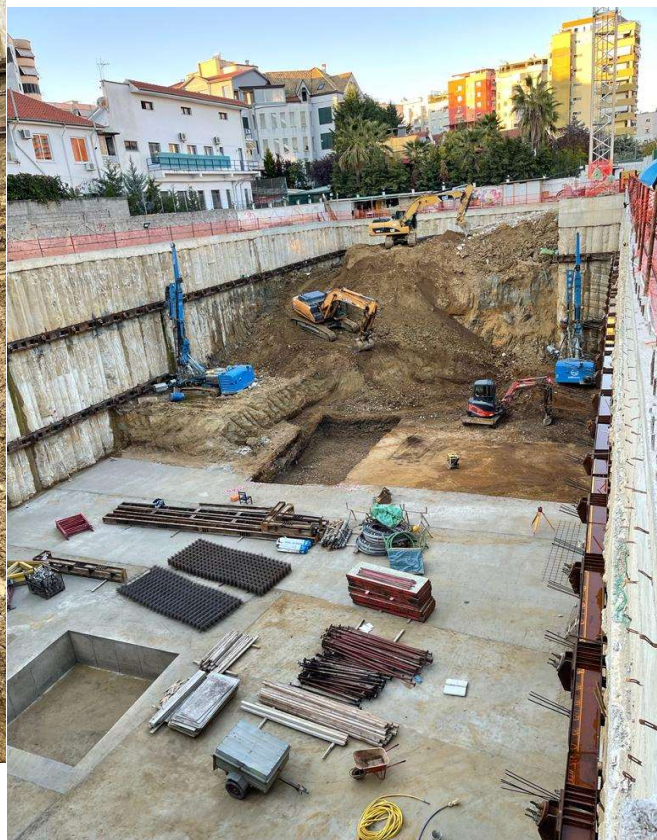
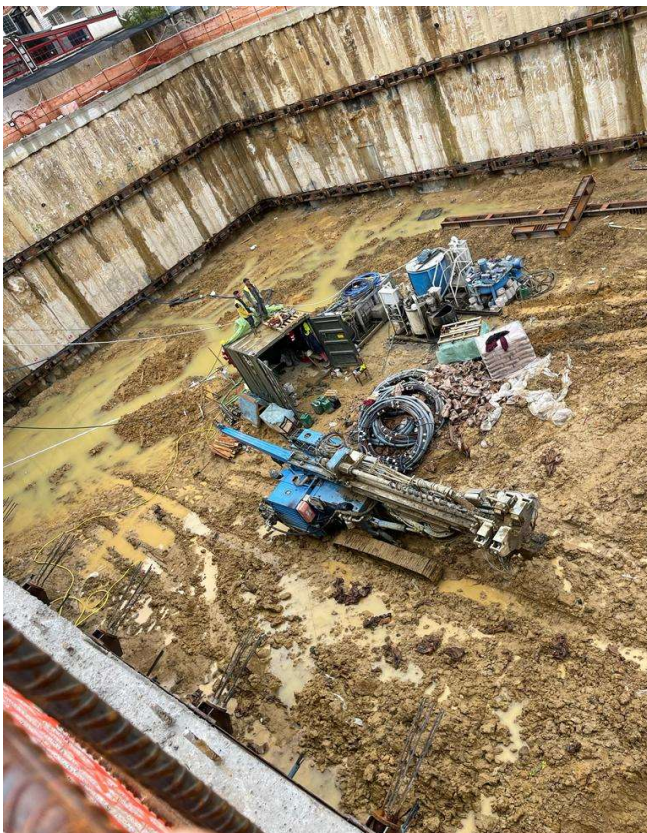
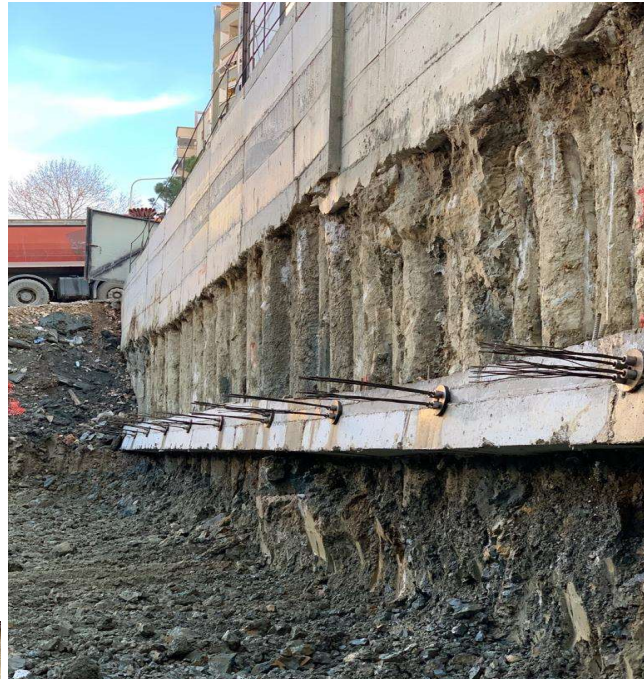

- **LDP Large Diameter Piles**

(LDP) Large Diameter Piles performed with telescopic kelly bar and drilling tool (auger, bucket, core barrell) is the most commonly used technology throughout the world, as it allows to drill piles in any type of soil or rock. Bored pile is a cast-in-place concrete pile where the bored piles have to be cast on job site.

The operating sequence includes the following steps: boring – generally using steel casing or stabilizing mud such as bentonite suspension – drilling and for uncased piles mud de-sanding. After these, reinforcement bar will be put into the bore hole and concrete will be poured into the bore hole.



Advantages

Telescopic kelly bar allows to perform very deep piles.

- Extensive range of drill tools, casings and other auxiliary equipment suited to any type of soil or rock.
- The large diameter bored piles are often applied in the execution of foundations of piles for bridges and viaducts in the water.

Length and diameter can be readily varied to suit varying ground conditions.

- Large excavations and subsequent backfill are eliminated.
- Absence of vibration will not disturb adjacent piles or structures.
- Offer higher capacities with potentially better economics than driven piles.

Technical data

Pile diameter: 600 to 3500 mm depending on soil diameter and consistency.

Pile depth: 60 to 100 m depending on soil diameter and consistency

Equipments

- Drilling Rig Soilmec SR95 - 1 Unit
- Drilling Rig Soilmec SR75 - 1 Unit
- Drilling Rig Soilmec SR45 - 1 Unit
- Drilling Rig MAIT HR130 - 2 Units
- Drilling Rig Soilmec R208 - 1 Unit
- Crawler Crane Casagrande C600HD - 1 Unit
- Crawler Crane SENNEBOGEN 3300 Star-Lifter - 1 Unit
- Crawler Crane SENNEBOGEN 5500 - 3 Units
- Crawler Crane ZOOMLION QUY70 - 1 Unit
- Crawler Crane Liebherr - 1Unit
- Vibrator Muller 24 Hz - 1Unit
- Vibrator PTC 20HZ - 1unit
- Caterpillar Excavator 320 D - 1 Unit
- KOMATSU PC138us Excavator - 1Unit
- Liebherr 550 wheel loader - 1 Unit
- Liebherr 542 wheel loader - 1 Unit
- HIDROMEK 102B wheel loader - 1 Unit
- Mercedes Benz Truck with 8 tons telescopic Crane - 1 Unit
- VOLVO pulling truck with semi trailer - 1 Unit
- Micropiles Rig Soilmec SM-14 - 1 Unit
- Micropiles Rig CMV 2000 - 1 Unit
- HIMONSA ELECTRIC GENERATOR - 5 units
- AIR Compressor Atlas Copco 416 - 2 units
- AIR Compressor Atlas Copco 146 - 1 Unit
- AIR Compressor Atlas Copco 336 - 1 Unit
- AIR Compressor Atlas Copco 186 - 2 Units
- DMillar Jet Water Pumps - 5 Units

Completion equipment:

- 5 motorized Wellpoint pumps 2 cylinders
- 2 motorized pump VM 6 cylinders
- 4 mono cylindrical pumps
- 4 moto welding MOSA
- 4 generators 50 kw
- Professional Welding equipment
- Flush continuous welding (argon)
- Jackhammer for 10 ton excavator
- 30 meters casing 1300 mm
- 60 meters casing 1000 mm
- 60 meters casing 900 mm
- 126 meters casing 800 mm
- 60 meters casing 640 mm
- Tools and casing 400 mm up to 1500 mm

- **Construction of stone columns - Engineered Ground Improvement**

Our strength lies in the field of Stone Columns and Vibro Compaction too. A mix of ground improvement techniques is often the key to a successful design-build approach.

We offer the whole range of services for the ground improvement, from construction of stone columns by top feed method, construction of stone columns bottom feed method, sand compaction, rigid inclusions by CFA etc.

- **Top Feed Stone Columns**

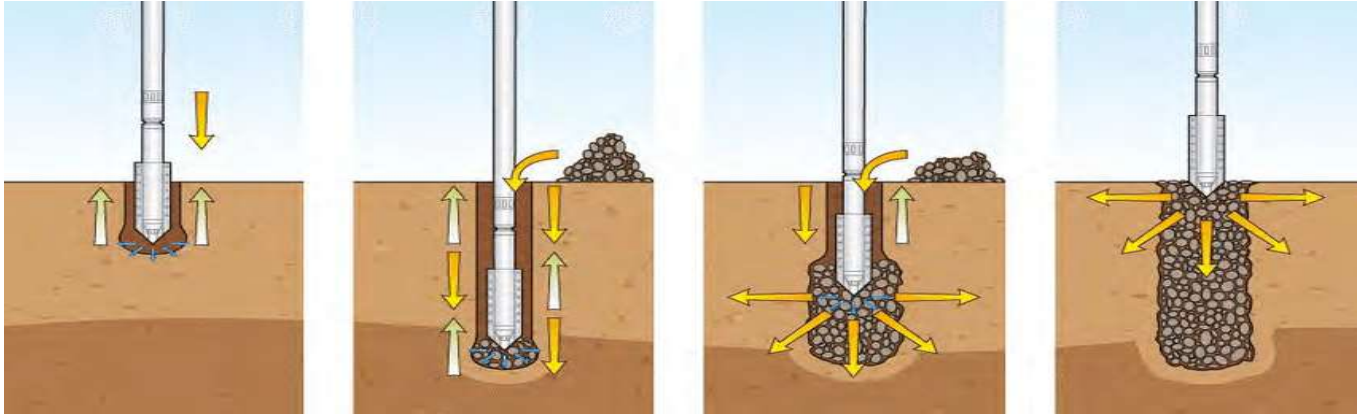

Penetration

The vibroflot penetrates and 'washes' the hole in preparation for the stone transport within the hole.

Installation

During the introduction of the stones, water and air are flushing in order to create a positive flow for the stone transport.

Completion

The vibroflot is frequently moved up and down in order to form and compact a column. Thereby, the surrounding ground is horizontally compressed and improved. The column is able to support high vertical loads.

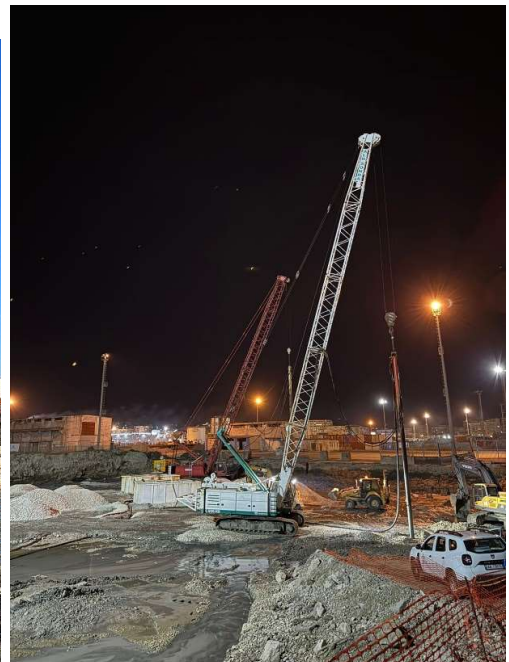

Works during construction of top feed stone columns for Durres Yacht and Marina project



Works during construction of top feed stone columns for Gjader Project

- Bottom Feed Stone Columns

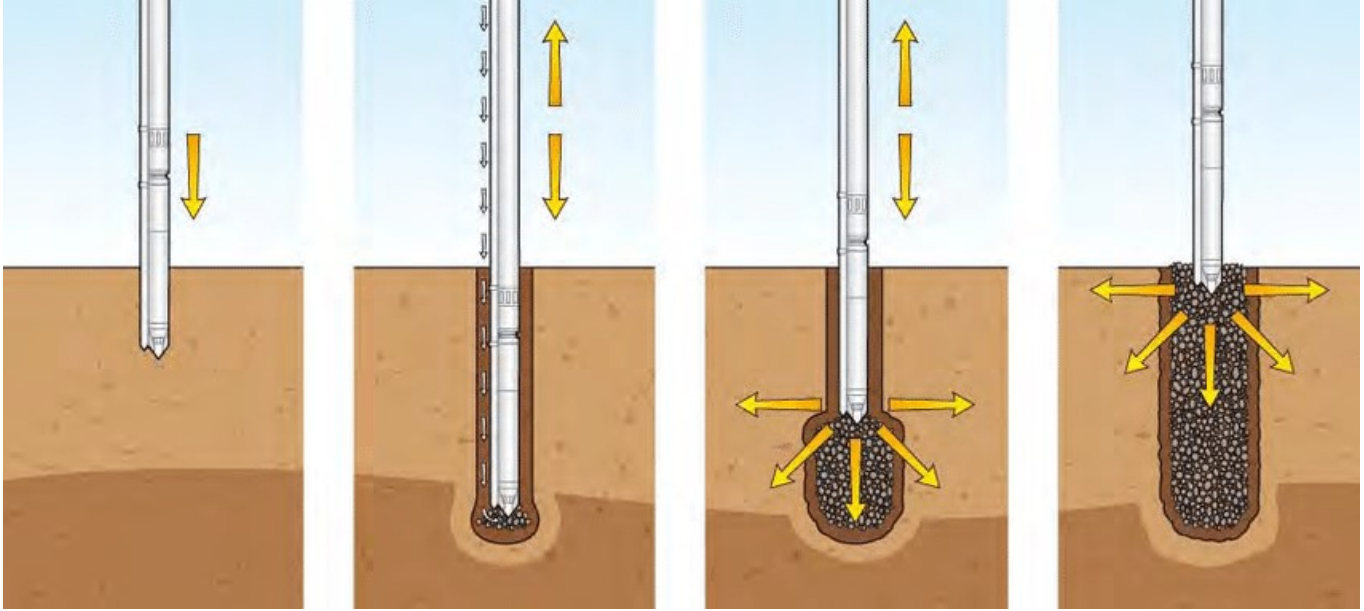
**Penetration**

The vibroflot penetrates with the help of vibration and air flushing. (Sometimes minimal water lubrication is useful to overcome high friction from the soils).

Installation

The stones are introduced via a tremie pipe along the vibroflot and the aid of pressurized air.

Completion

The vibroflot is frequently moved up and down in order to form and compact a column. Thereby, the surrounding ground is horizontally compressed and improved. The column is able to support high vertical loads.

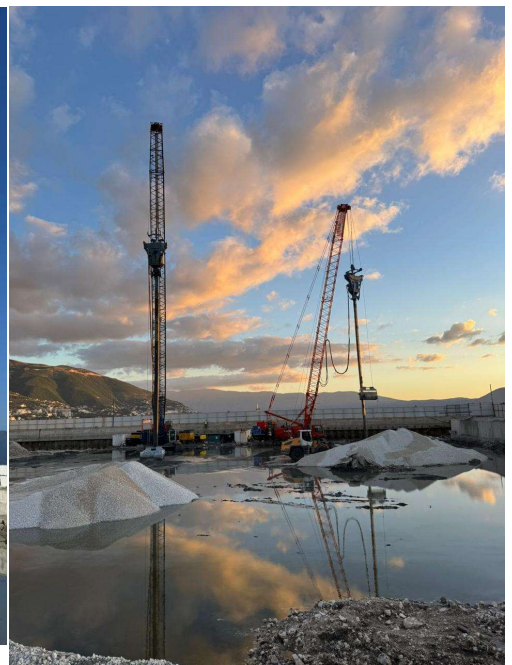
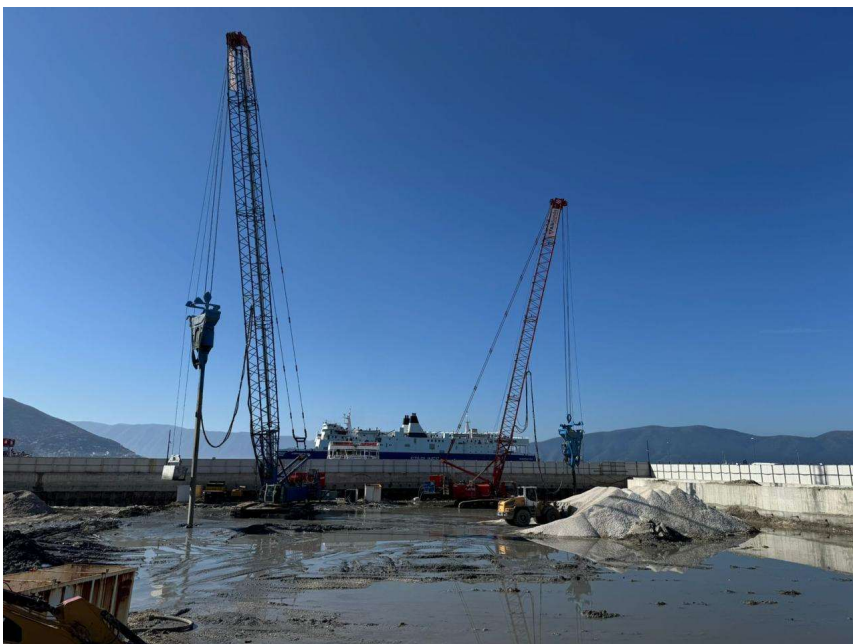

Works during construction of bottom feed stone columns for Vlora Marina project

Stone Columns represent the most natural and ecologically neutral foundation system in existence due to consisting entirely of natural stones.

Sufficient quality gravel or crushed rock for producing quality Stone Columns are widely available in many areas. The ecological balance can be further improved through the use of recycled concrete material.

STONE COLUMN PROJECTS:

1- Durres Yacht and Marina by EMAAR Group

Construction of 2400 pieces of Stone Columns, Length 15m - 22m - Top feed method

Job completed in 15 March 2024.

2- Gjader Refugees camp

Construction of more than 6000 stone column piles, Length 12m-18m - Top feed method

Job completed in July 2024

3- Vlora Marina and Residences

Construction of 1922 stone column piles - first building, Length 30m - Bottom feed method

Ongoing project - In total to be constructed more than 10.000 stone column piles, length 30m

4- Biox Acque Reflue - Augusta, Sicily, Italy

Construction of 25.000 linear meter stone columns, length 16m - Bottom feed method

5- Durres Yacht and Marina

Construction of 100.000 linear meters stone columns for beach reclamation area, length 25m - Bottom feed method.

Ongoing project

AlbSonda is the official and exclusive partner of Betterground in Albania and Balkan region.

List of machineries and equipment for construction of stone columns

Top feed method

- PTC Vibrolance VL18C free hanging - top feed hydraulic Vibroflot - penetration depth up to 30m (1 unit)



Technical specifications

Hydraulic power	113 / 154	kw / HP
Eccentric moment	1,5	kg.m
Operational frequency	50 / 3000	Hz / rpm
Centrifugal force	181	KN
Oil flow	189	l/min
Maximum pressure	360	bar
Total weight	2570	kg

Stone column diameter	450-800	mm
Treatment depth	8	m

Easy maintenance thanks to patented design "Hardox shields"

Option : air or water jetting

Option : 6m extension	1100	kg
-----------------------	------	----

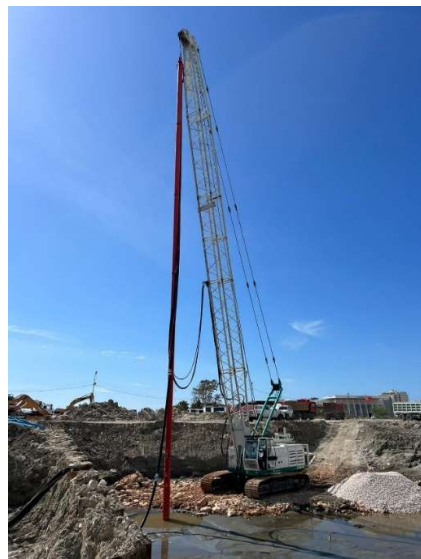
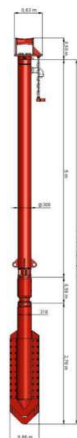

- BAUER hydraulic Vibroflot TR 75 and HD 470 powerpack - penetration depth up to 24m (1 unit)

Depth Vibrator TR 17 and TR 75

	TR 17	TR 75
Centrifugal force	kN 193	313
Eccentric moment	Nm 17	75
Amplitude at tip of vibrator	mm ± 6/12	± 11/22
Speed/frequency	rpm/Hz 3,215/53	1,950/32
Power output	kW 96	224
Overall weight incl. follower tube (VF)	kg ca. 6,700 (25 m)	ca. 15,300 (50 m)
Penetration depth	m up to 25	up to 50
Diameter of pre-bore if required	mm ~ 550	~ 750

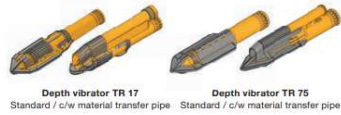
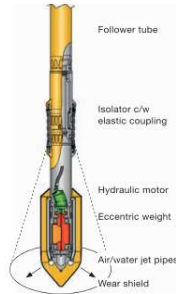

The horizontal vibrations of the depth vibrator are generated by a hydraulic motor driving an eccentric weight, housed inside the vibrator section. The length of the depth vibrator can be adjusted to suit the prevailing site conditions by the addition of follower tubes. Fully customized BAUER base machines provide the necessary hydraulic power without the need for auxiliary power packs. For use with external base machines, a suitably sized BAUER hydraulic power pack is recommended.

Hydraulic power packs

	HD 250	HD 470
Depth vibrator	TR 17	TR 75
Power output	kW 176	261/298
Hydraulic pressure	bar 320	330
Oil flow	l/min 250	470



Hydraulic power pack HD 250

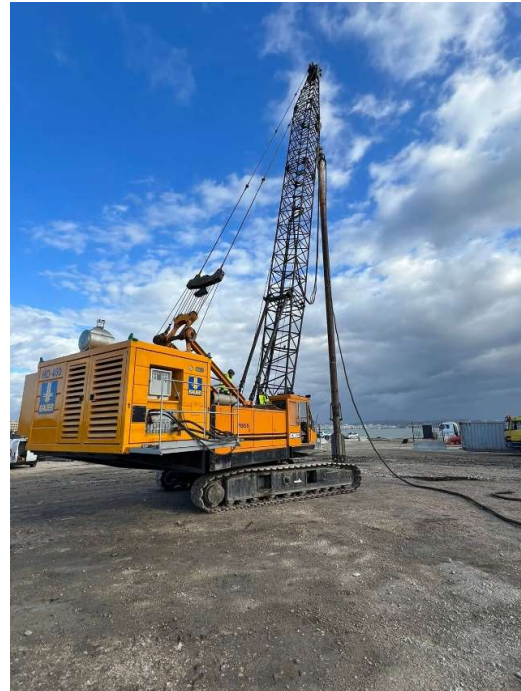

- Betterground B27 electric top feed Vibroflot - penetration up to 30m (2 units)

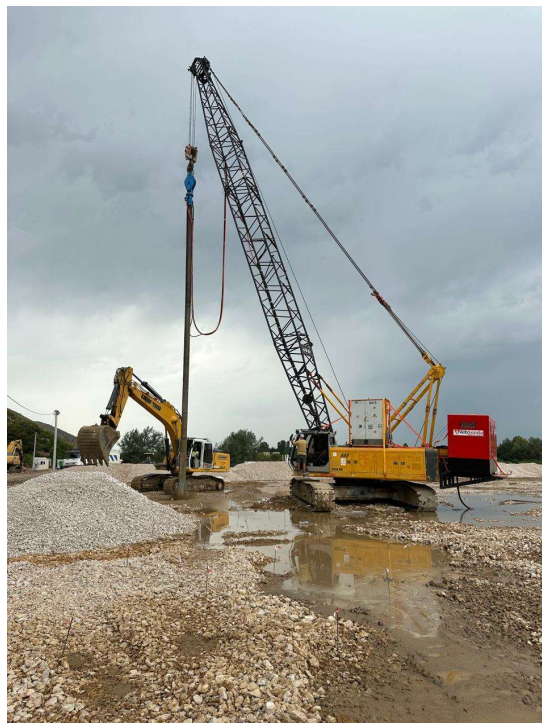
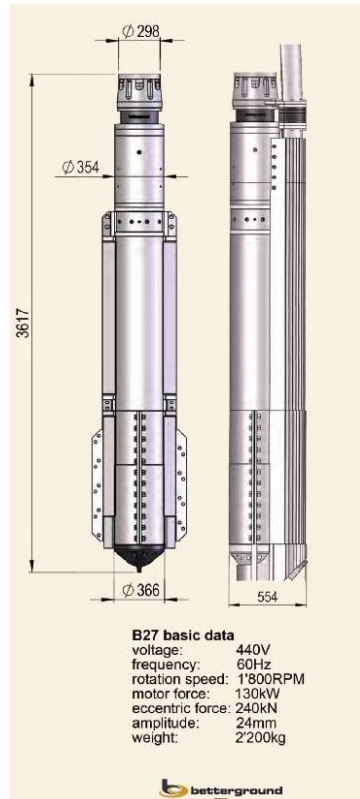

Quality Control Recorder - Stone Column Monitoring Printout

Continuous Recording of:

- Depth
- Amperage
- Air pressure in double lock system
- Inclination

The output can be analyzed in a custom made software or in Excel. Seen below, a magnified plot was created to better study the build up of Ampere during rig penetration and subsequent column installation.

A report is created and printed out after every stone column pile installation as below.

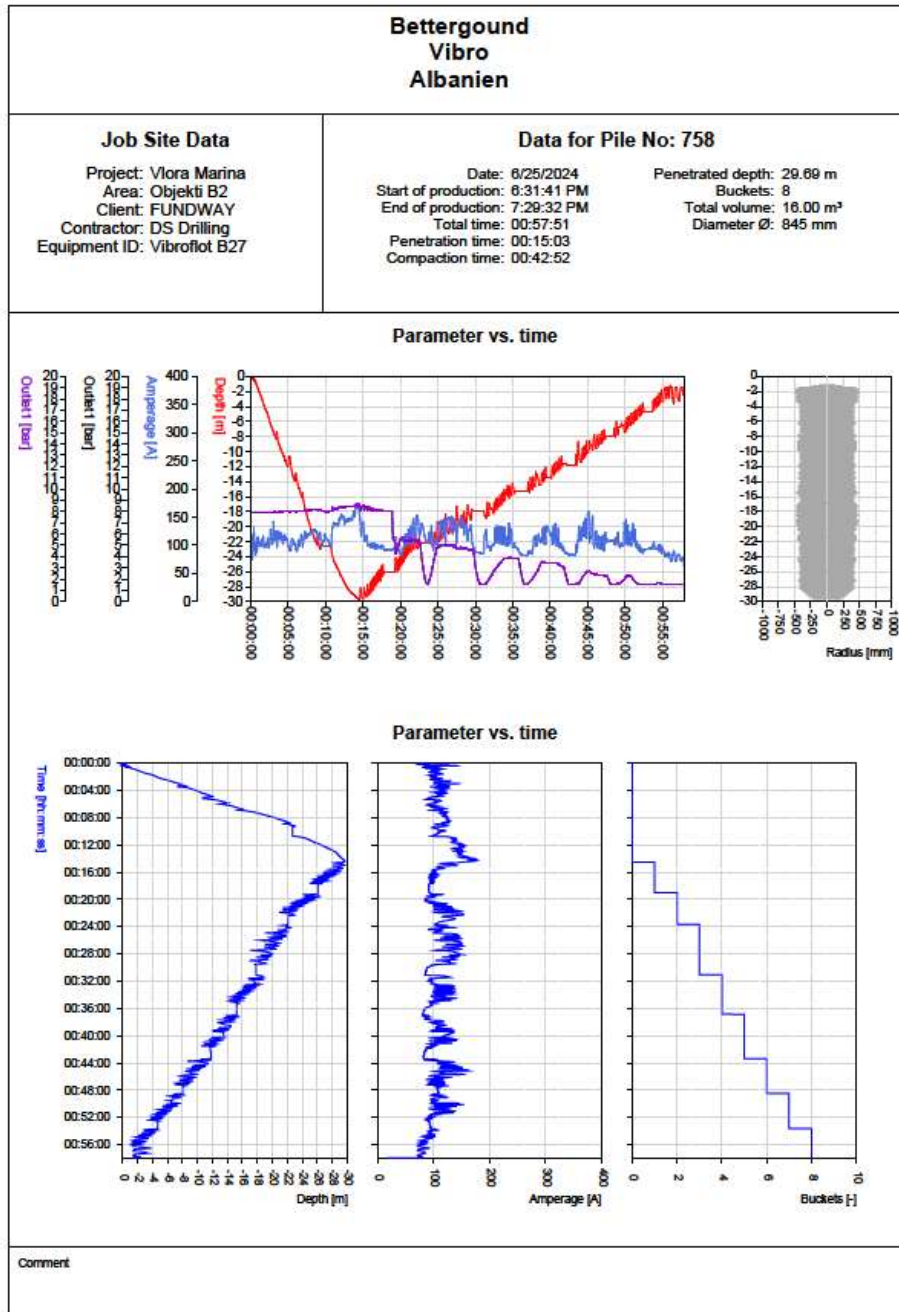

© Copyright 2015 - Gamperi & Hatapa GmbH - GUHMA Messdatenauswertung V3

- Sheet piles installation and steel open driven piles installation

AlbSonda was subcontracted by RENCO SPA in the project " TEMPORARY POWER SOLUTION FOR ALBANIA", as a main contractor for all the Civil works and some of the main activities are installation of sheet piles for a quantity approximately 8000 tons and the installation of the steel driven piles length 24m, d=925mm and th=27.2m in sea for the mooring system.

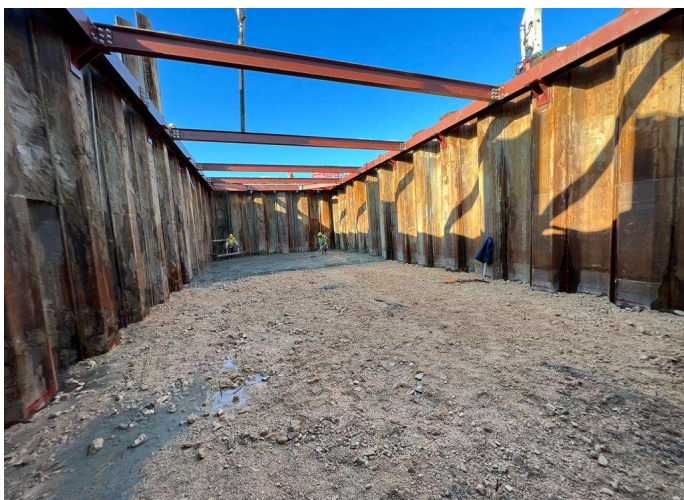
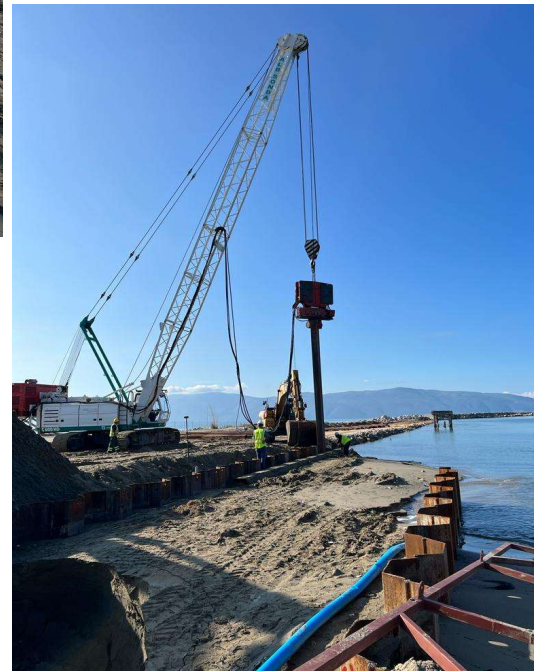
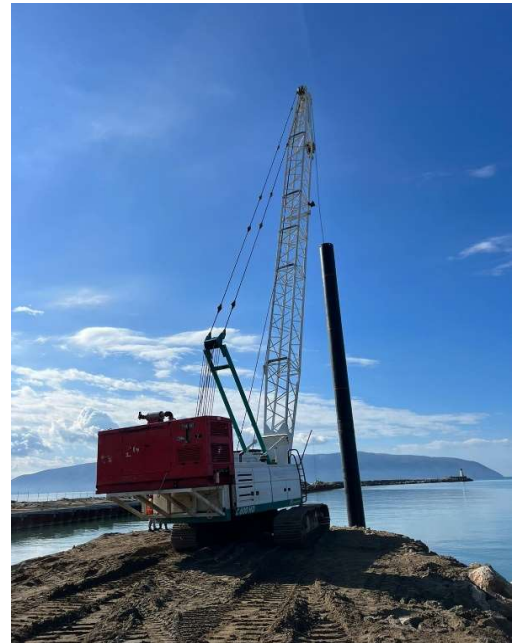

Some of our works

Below are listed some of our activities and completed works in the last years some, of our most used machines with respective members of company.

Porto Romano, Durres:
Bored Piles length 40m, d=1200mm
Client: Integrated Energy

Bridges foundation for Gramsh Hydroelectric plant.
Piles from 15 meters in diameter 1200 mm.
Client: Alb-Star

TAP pipeline Korce - Proger Gravel Piles for soil
improvement 8 meters in diameter 800 mm.,
Client: SPIECAPAG – AlbStar

Vlora Waterfront. Variation of piles of different sizes
and depths, excavation works with tracked vehicles for
waste water.(5.000 meter linear)
Client: Xh & M sh.p.k

International Stadium Air Albania – Tirana.
Piles 16 m length, diameter 800mm
Client: AlbStar

2 Oil Well Shpirag - Berat First drilling 40 meters in hard
rock 1400 mm diameter with 13 meter drive casing.
Installation and concreting the first casing 800mm for
drilling machine. Client: SHELL – AlbStar. Client:
Petromanas - AlbStar.

Acquaduct of Elbasan. Drilling piles and Wells 30
meters
Client: AlbStar

Marinz – Fier. Stands for refueling tanks. Piles 15 m in
length, 600 mm in diameter.
Client: AlbStar

GECI TOWER Foundations in Tirana
Secant bored piles, d=1000mm, length=30m
Client: GECI shpk

RENCO SPA
Main Contractor for RENCO for the Civil Works in the
project " Temporary Power Solution for Albania"

Pogradec water system
Bored Piles diameter 700mm, length 12m in rock
foundation
Client : STRABAG

Tirane - Elbasan Motor way
Bridges foundation with bored piles, d=1000mm,
length 18m
Client: 2T shpk

International Stadium Air Albania – Tirana.
Piles 16 m length, diameter 800mm
Client: AlbStar

Tirane - Elbasan Motor way
Bridges foundation with bored piles, d=1200mm,
length 15m
Client: AKTOR

Rrapun 3 and 4 Hydropower
Bored piles in diameter 900mm, length from 12 to 18m
Client: AKTOR

Thumane - Kashar Motorway
Bored Piles with casing for bridges foundations
diameter 1200mm and length 24m
Client : Gener 2

Tirane - Rinas - Durres Railway
Bored piles in diameter 1200mm, length 22m
Client : Kichberger

PHOTO GALLERY

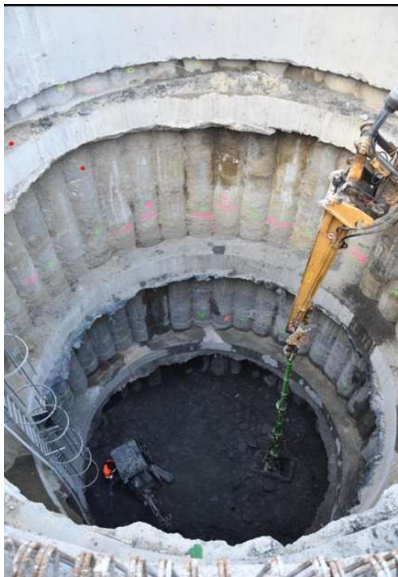

Works during the Trans Adriatic Pipeline Construction (2020)

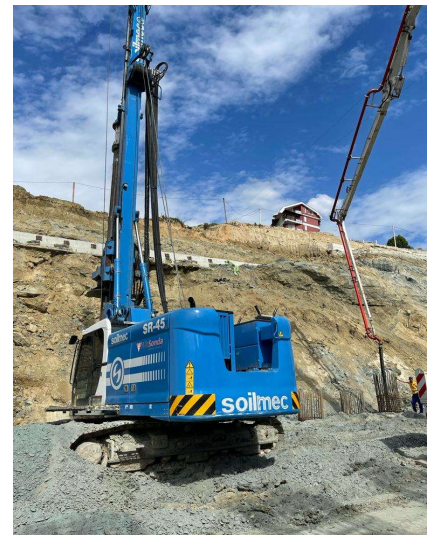
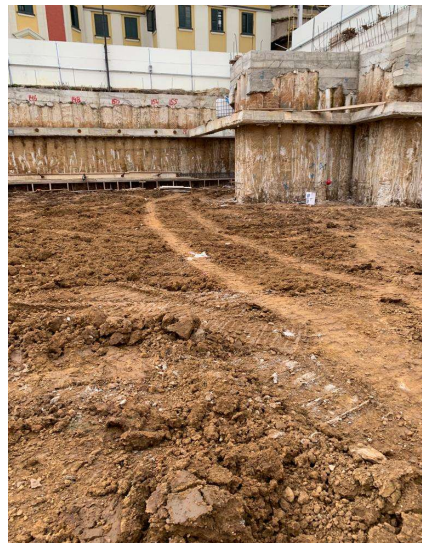
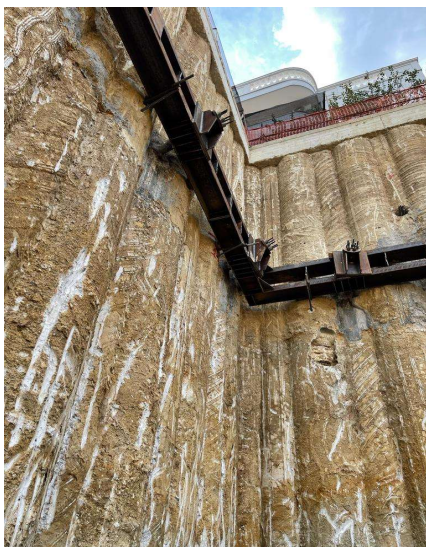
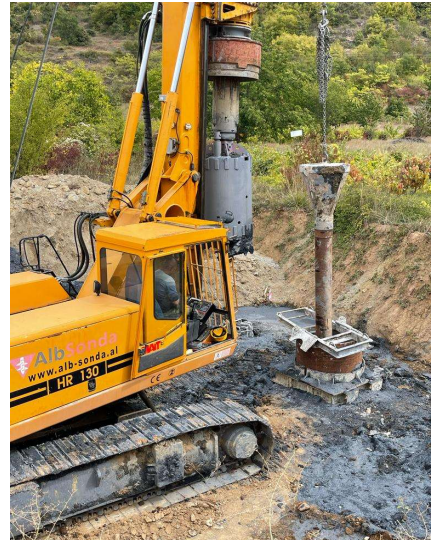

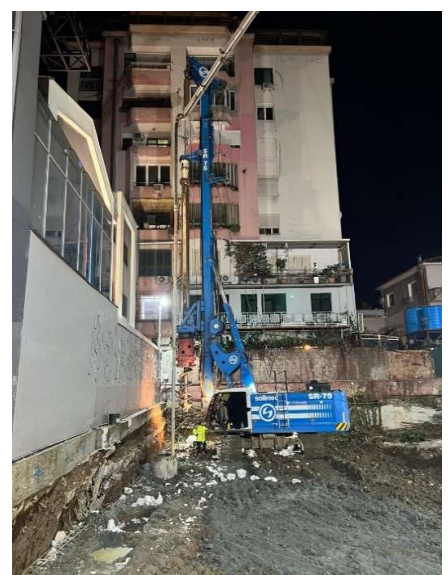
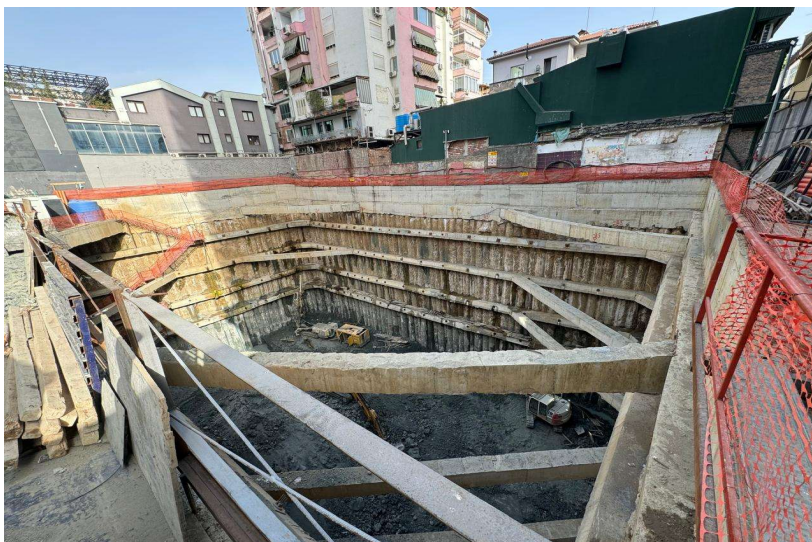
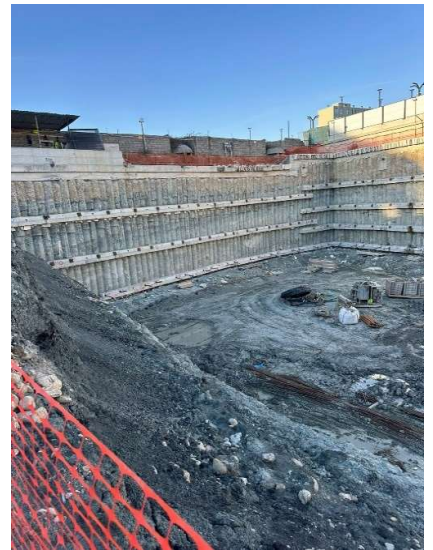
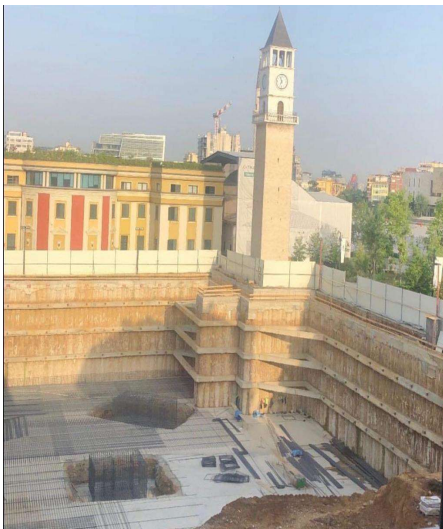
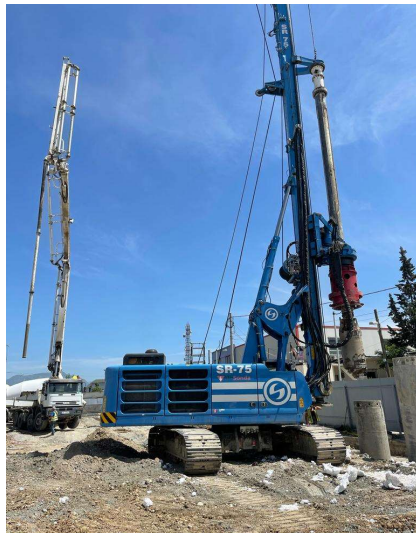

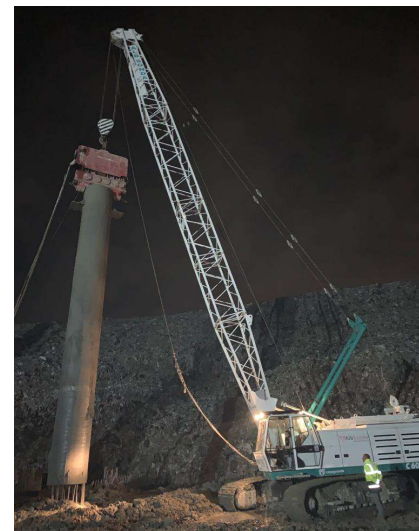
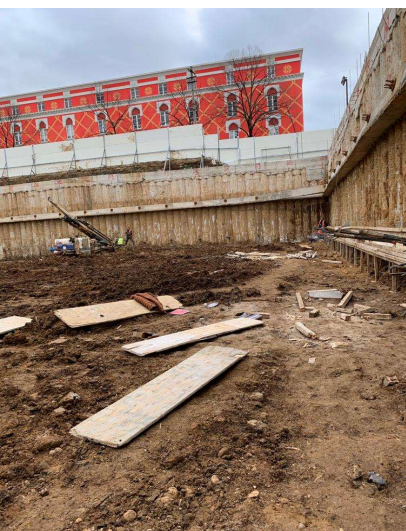

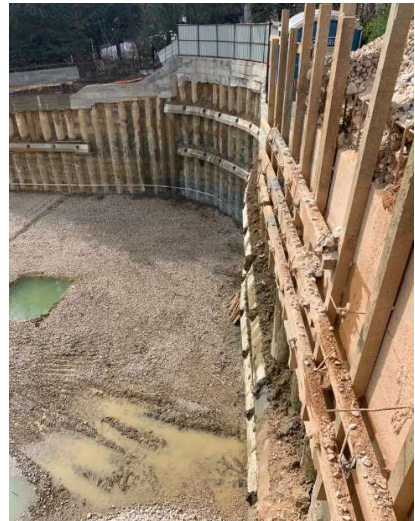
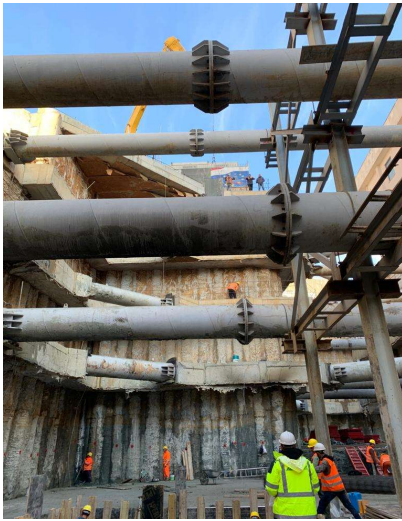
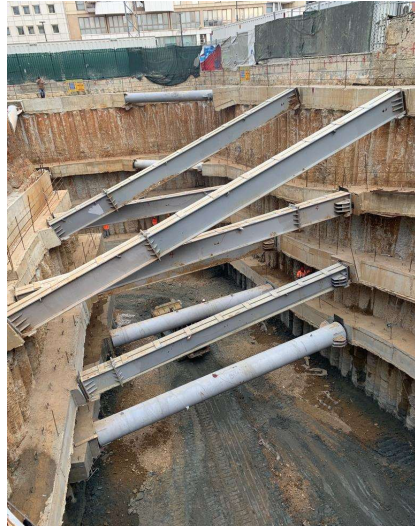
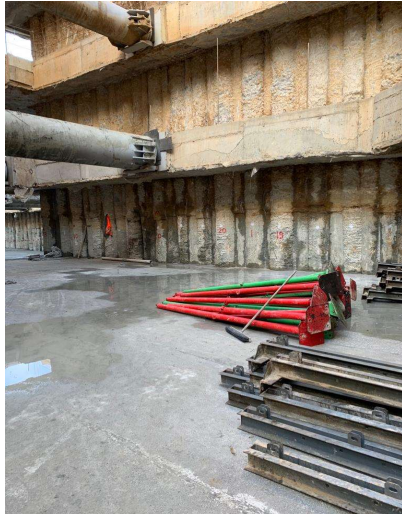
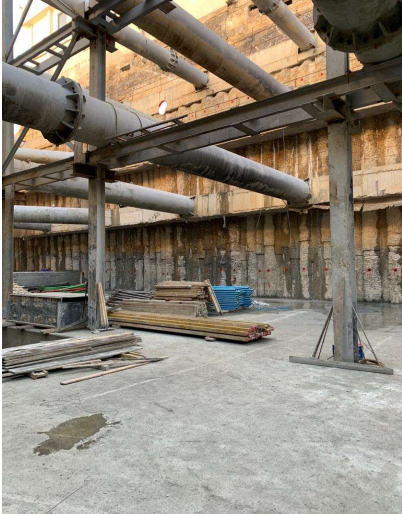

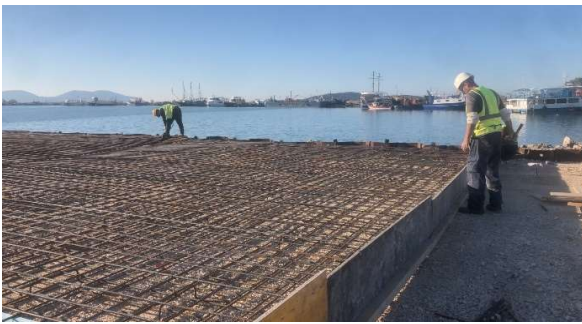

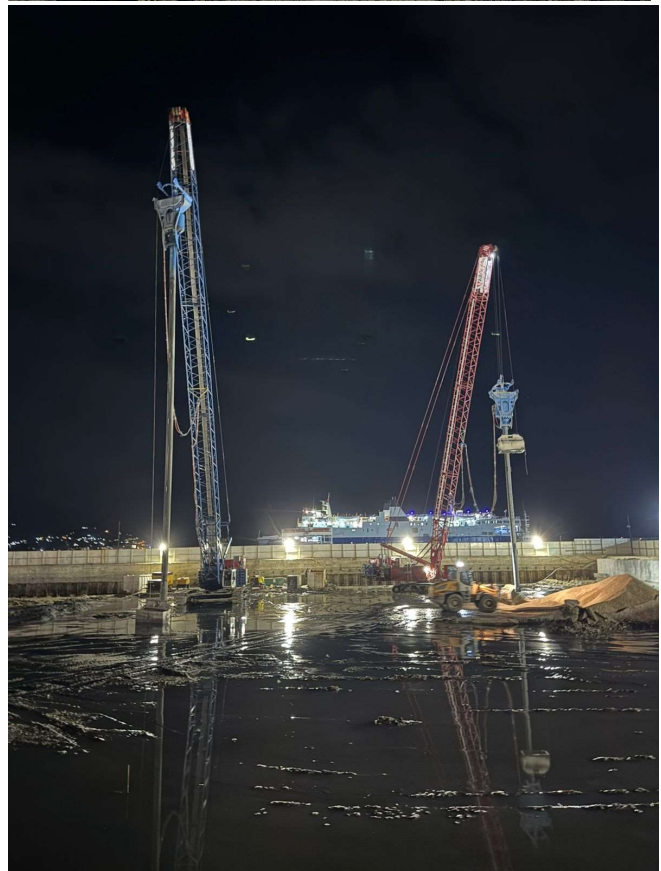
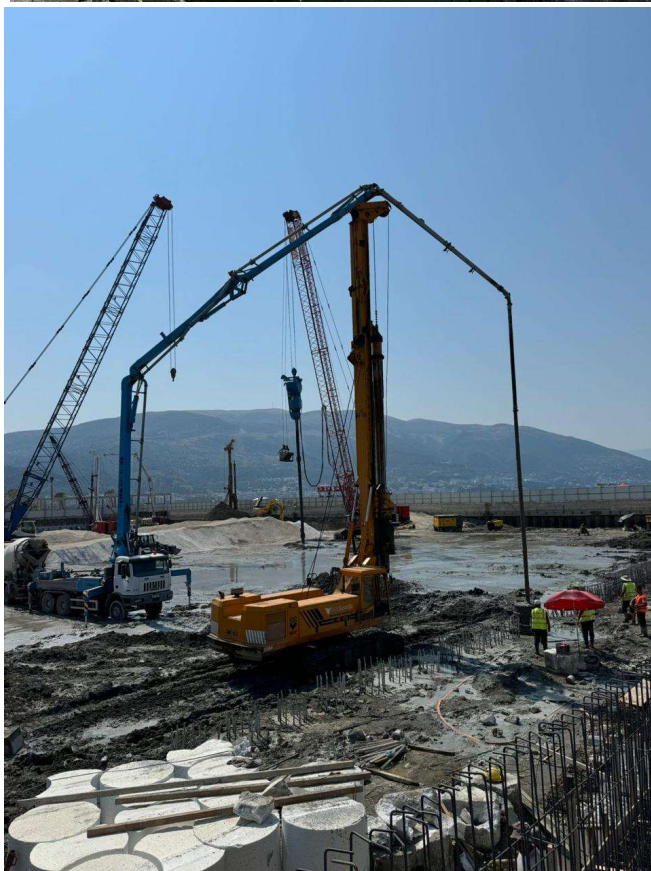
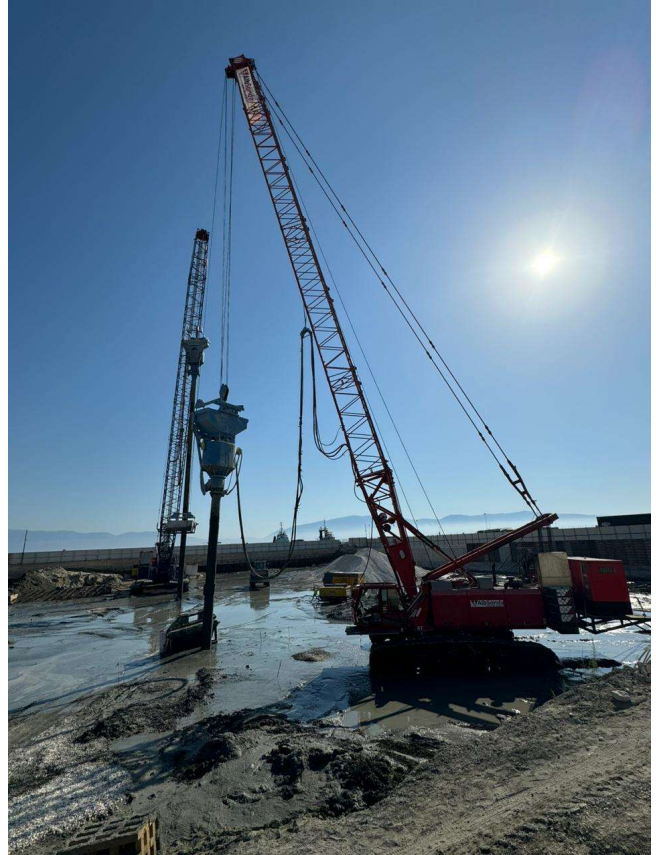
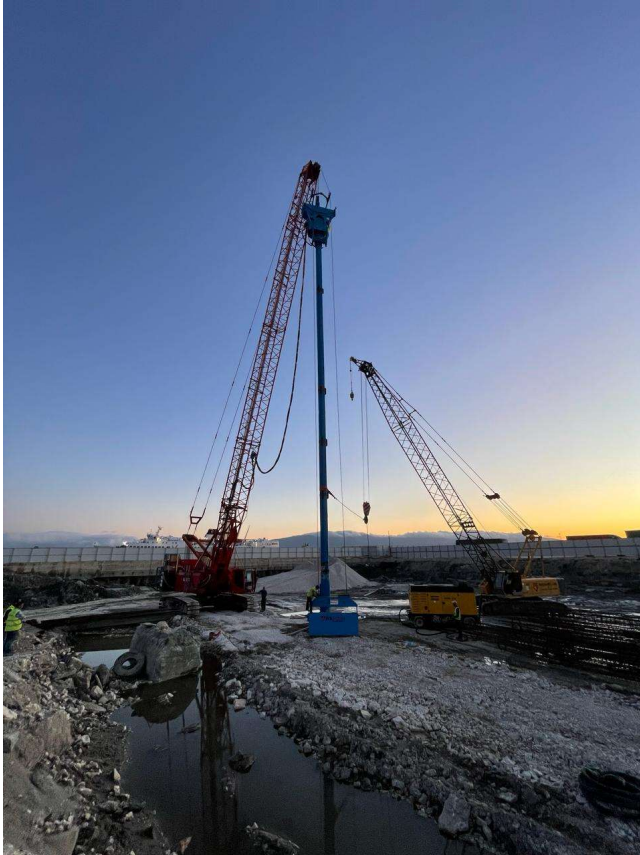

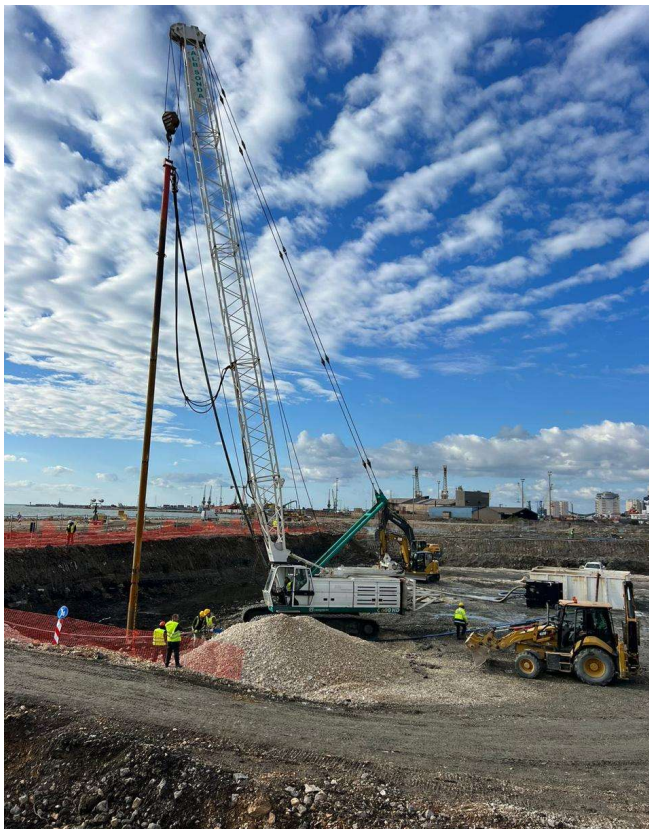
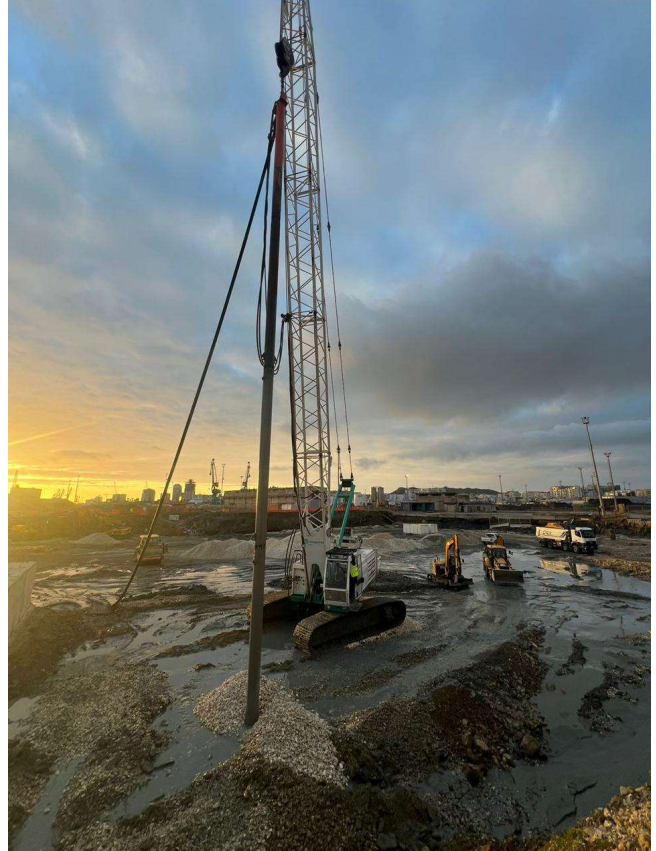
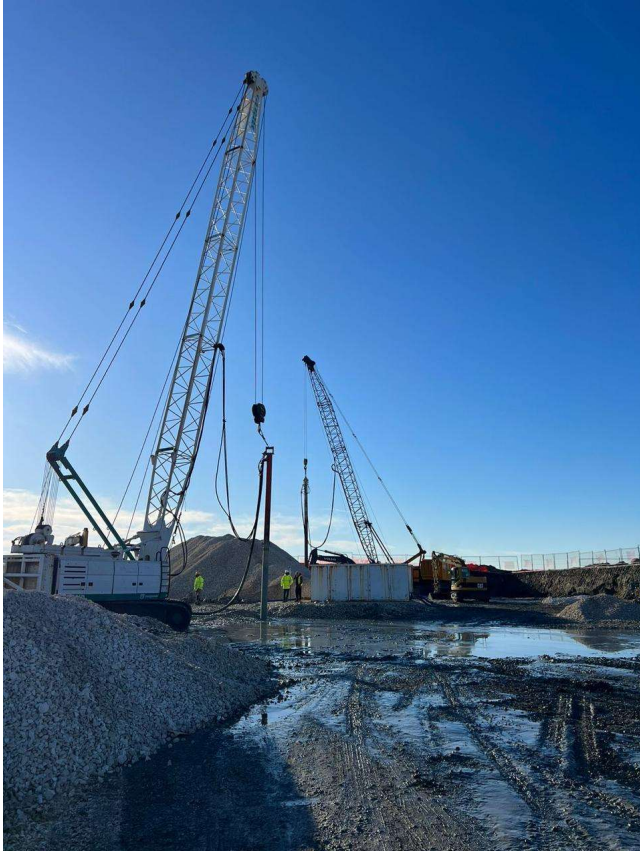

Our Partners



